

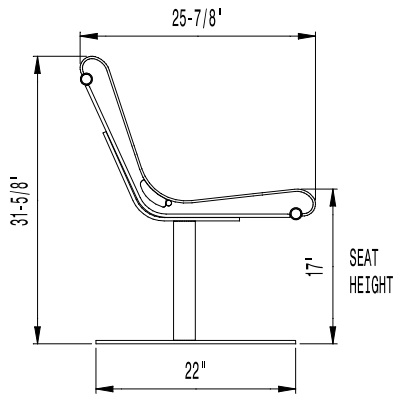

**VICTOR STANLEY, INC.®**  
*-Manufacturers of Quality Site Furnishings since 1962-*

P.O. DRAWER 330 - DUNKIRK, MD 20754 USA  
 TOLL FREE: (800) 368-2573 (USA & CANADA)  
 TEL (301) 855-8300 - FAX (410) 257-7579  
 WEB SITE: HTTP://WWW.VICTORSTANLEY.COM

\* ALL DIMENSIONS ARE IN INCHES \*



STEEL SLATS ARE FORMED FROM 1/4" x 1-1/2" SOLID STEEL BARS

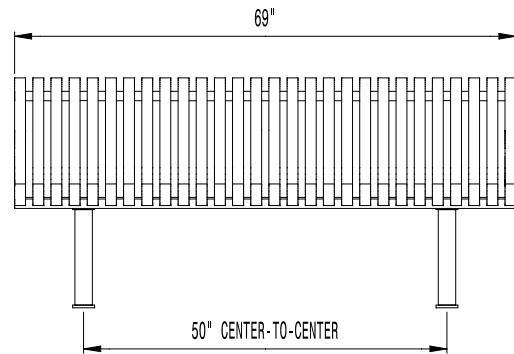
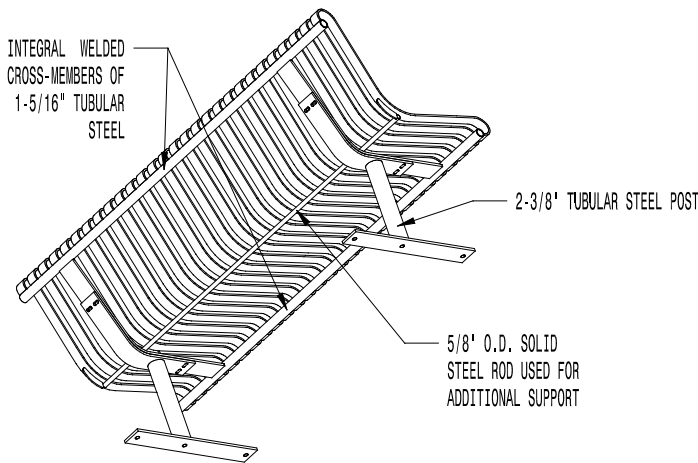
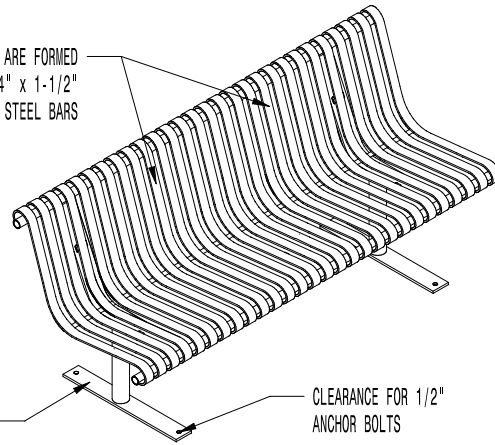

**AVAILABLE OPTIONS:**

**POWDER COATING**

10 STANDARD COLORS, 2 OPTIONAL METALLIC COLORS, CUSTOM COLORS (INCLUDING THE RAL RANGE)

**INTERMEDIATE ARMRESTS**

4', 6', & 8' AVAILABLE WITH OPTIONAL ARMRESTS

**LENGTHS**

STANDARD 4'  
 STANDARD 6' LENGTH SHOWN  
 STANDARD 8'

**MOUNTING**

STANDARD IN-GROUND AND SURFACE (AS SHOWN)  
 AVAILABLE WITH OPTIONAL GULL-WING AND WALL

**NOTES:**

1. DRAWINGS NOT TO SCALE. DO NOT SCALE DRAWINGS.
2. ALL FABRICATED METAL COMPONENTS ARE STEEL SHOTBLASTED, ETCHED, PHOSPHATIZED, PREHEATED, AND ELECTROSTATICALLY POWDER-COATED WITH T.G.I.C. POLYESTER POWDER COATINGS. PRODUCTS ARE FULLY CLEANED AND PRETREATED, PREHEATED AND COATED WHILE HOT TO FILL CREVICES AND BUILD COATING FILM. COATED PARTS ARE THEN FULLY CURED TO COATING MANUFACTURER'S SPECIFICATIONS. THE THICKNESS OF THE RESULTING FINISH AVERAGES 8-10 MILS (200-250 MICRONS).
3. IT IS NOT RECOMMENDED TO LOCATE ANCHOR BOLTS UNTIL BENCH IS IN PLACE. THIS VICTOR STANLEY, INC. PRODUCT MUST BE PERMANENTLY AFFIXED TO THE GROUND. CONSULT YOUR LOCAL CODES FOR REGULATIONS.
4. ANCHOR BOLTS NOT PROVIDED BY VICTOR STANLEY, INC.
5. FOR HIGH SALT ABUSIVE CLIMATES, HOT DIP GALVANIZING BEFORE POWDER COATING IS AVAILABLE. SEE WRITTEN SPECIFICATIONS FOR DETAILS.
6. ALL SPECIFICATIONS ARE SUBJECT TO CHANGE. CONTACT MANUFACTURER FOR DETAILS.
7. THIS PRODUCT IS SHIPPED PARTIALLY UNASSEMBLED.

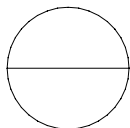

**NRB-6**

STEELSITES™ SERIES

STEEL SLAT BENCH  
 SHOWN: STANDARD 6-FOOT LENGTH  
 STANDARD SURFACE MOUNT