

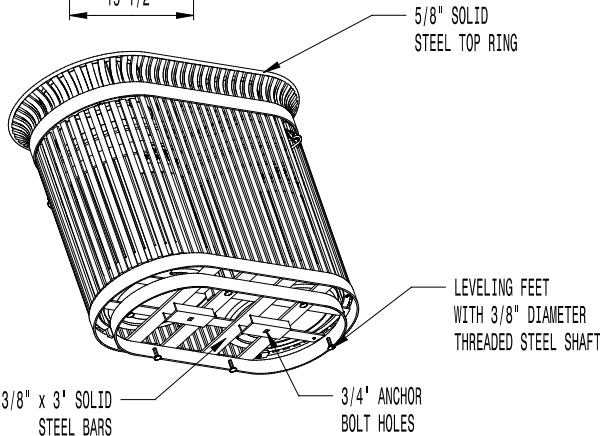

**VICTOR STANLEY, INC.®**  
*-Manufacturers of Quality Site Furnishings since 1962-*

P.O. DRAWER 330 - DUNKIRK, MD 20754 USA  
 TOLL FREE: (800) 368-2573 (USA & CANADA)  
 TEL (301) 855-8300 - FAX (410) 257-7579  
 WEB SITE: HTTP://WWW.VICTORSTANLEY.COM

\* ALL DIMENSIONS ARE IN INCHES \*

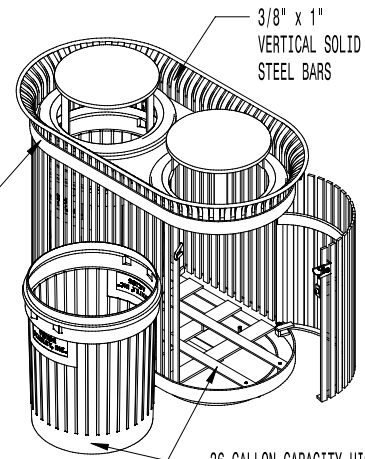
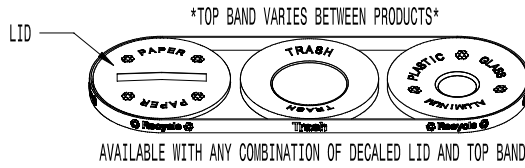
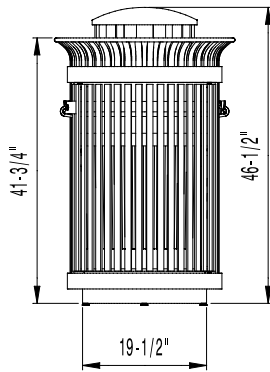

1/4" x 2-1/2"  
HORIZONTAL SOLID  
STEEL BANDS

3/8" x 1"  
VERTICAL SOLID  
STEEL BARS

36-GALLON CAPACITY HIGH  
DENSITY PLASTIC LINER  
(WEIGHT NOT TO EXCEED 6 LBS.)  
SITS ON 1/4" x 2" SUPPORT BARS

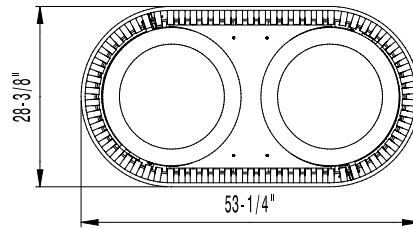

**AVAILABLE OPTIONS:**

POWDER COATING

10 STANDARD COLORS, 2 OPTIONAL METALLIC COLORS,  
CUSTOM COLORS (INCLUDING THE RAL RANGE)

SECURITY

STANDARD WITH LOCKABLE LATCH (AS SHOWN). AVAILABLE WITH OPTIONAL KEYED  
LOCK BOX. LID BOLTED IN PLACE. AVAILABLE WITH OPTIONAL MOUNT WITH  
3 IN-LINE ANCHOR HOLES AND OPTIONAL BOTTOM PLATE COVER.

**LIDS**

STANDARD WITH TAPERED FORMED LID. AVAILABLE WITH OPTIONAL DOME LID (AS SHOWN),  
DOME LID WITH ASHTRAY, RAIN BONNET LID, RAIN BONNET LID WITH ASHTRAY, CONVEX LID,  
CONVEX LID WITH SELF CLOSING DOOR, ENCLOSED DOME LID, ENCLOSED DOME LID WITH  
STAINLESS STEEL ASHTRAY, AND RECYCLE LIDS. ASHTRAYS AVAILABLE WITH  
OPTIONAL ASHTRAY COVER.

**CUSTOM PLAQUES & DECALS**

AVAILABLE WITH STEEL PLAQUES IN VARIOUS SIZES AND PRESSURE SENSITIVE  
VINYL OUTDOOR DECALS.

**NOTES:**

1. DRAWINGS NOT TO SCALE. DO NOT SCALE DRAWINGS.
2. ALL FABRICATED METAL COMPONENTS ARE STEEL SHOTBLASTED, ETCHED, PHOSPHATIZED, PREHEATED, AND ELECTROSTATICALLY POWDER-COATED WITH T.G.I.C. POLYESTER POWDER COATINGS. PRODUCTS ARE FULLY CLEANED AND PRETREATED, PREHEATED AND COATED WHILE HOT TO FILL CREVICES AND BUILD FILM COATING. COATED PARTS ARE THEN FULLY CURED TO COATING MANUFACTURER'S SPECIFICATIONS. THE THICKNESS OF THE RESULTING FINISH AVERAGES 8-10 MILS (200-250 MICRONS).
3. OIL IMPREGNATED BRONZE BUSHINGS AND STAINLESS STEEL PIVOT PINS FOR DOOR MOVEMENT, STANDARD 3/16" SOLID STEEL LATCH ASSEMBLY OR OPTIONAL PATENTED STAINLESS STEEL KEYED LOCK ASSEMBLY.
4. THIS VICTOR STANLEY, INC. PRODUCT MUST BE PERMANENTLY AFFIXED TO THE GROUND. CONSULT YOUR LOCAL CODES FOR REGULATIONS.
5. VICTOR STANLEY, INC., PLASTIC INNER LINERS ARE MOLDED ON TOOLING DESIGNED FOR AND OWNED BY VICTOR STANLEY, INC. THEY OFFER MAXIMUM CAPACITY AND STRENGTH WITH LIGHTWEIGHT CONSTRUCTION USING CRITICAL MOLDED RIBS, INTEGRAL HANDHOLDS, AND HIGH-STRENGTH MATERIALS. THIS MINIMIZES HANDLING DIFFICULTY AND FACILITATES EASY EMPTYING AND STORAGE WHILE AFFORDING LONG SERVICE LIFE.
6. ANCHOR BOLT NOT PROVIDED BY VICTOR STANLEY, INC.
7. FOR HIGH SALT ABUSIVE CLIMATES, HOT-DIP GALVANIZING BEFORE POWDER COATING IS AVAILABLE. HOT-DIP GALVANIZING IS PERFORMED FOR VICTOR STANLEY, INC. BY AN EXPERIENCED QUALIFIED FIRM TO WHICH PRODUCTS ARE SHIPPED FOR GALVANIZING. HOT-DIP GALVANIZING INCLUDES AN AGGRESSIVE PRE-TREATMENT AND IMMERSION IN A TANK OF CHARGED LIQUID ZINC AT OR AROUND 860°F (460°C). THE RESULTING SURFACE IS RESISTANT TO RUST BUT HAS SOME UNEVENNESS RESULTING FROM THE BONDING OF THE ZINC TO THE STEEL SURFACE. AS A RESULT, THE POWDER-COATING SURFACE FINISH OVER THAT GALVANIZED SURFACE MAY EXHIBIT BUMPS, UNEVENNESS, AND MAY NOT BE AS SMOOTH AS THE STANDARD FINISH; THIS UNEVEN AND INCONSISTENT FINISH IS NORMAL FOR GALVANIZING. CONTACT MANUFACTURER FOR DETAILS.
8. ALL SPECIFICATIONS ARE SUBJECT TO CHANGE. CONTACT MANUFACTURER FOR DETAILS.
9. THIS PRODUCT IS SHIPPED FULLY ASSEMBLED.

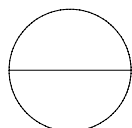

**SD-242**

IRONSITES® SERIES

SIDE-DOOR RECYCLING STATION  
 SHOWN: (2) OPTIONAL DOME LID